

PLAN VIEW

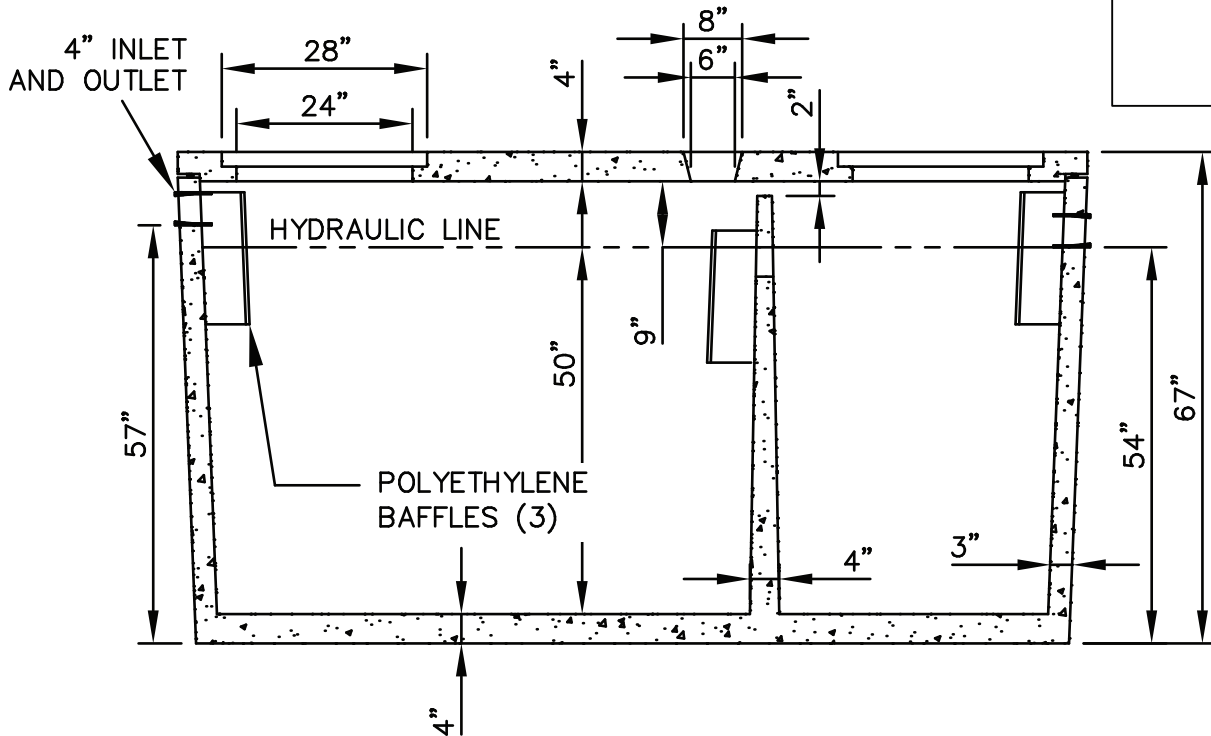
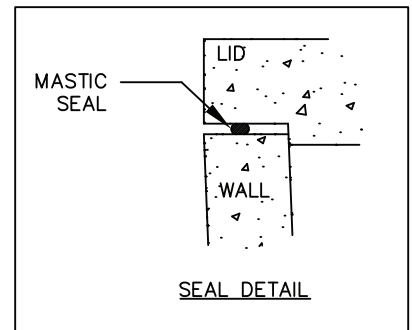

SECTION VIEW

Non-Traffic Rated, 4 Feet Maximum Cover. Risers, Riser Lids, Pipes & Fittings Sold Separately

**PRECAST  
TRANSPORTATION  
SOLUTIONS**

322 Bynum Road  
Forest Hill, Maryland 21050  
Phone: 410-838-3007

**STANDARD PROFILE  
PRECAST 1500 GALLON SEPTIC TANK  
TWO COMPARTMENT**

[www.precasttransportationsolutions.com](http://www.precasttransportationsolutions.com)